

MITSUBISHI Mechanical Drive Steam Turbine



MCO Web site:
<http://www.mhicompressor.com/>





Technical evolutions of Steam Turbine

Mitsubishi Mechanical Drive Steam Turbine

Mitsubishi Heavy Industries Compressor Corporation (MCO) has been building steam turbines for almost one century. Mitsubishi mechanical drive steam turbines are being accepted favorably as smooth, economical, reliable turbines by all our customers.

Today, MCO is one of the leading manufacturers of steam turbines of all types. The first mechanical drive turbine from our Works was delivered in 1958. Since then, we are a leading global provider of steam turbines for the petrochemical industry and oil & gas field. Mitsubishi steam turbines have established a world-class reputation for reliability and high performance achieved through cutting edge technologies.

Advantage of Mitsubishi Mechanical Drive Steam Turbine

- Stable superior performance
- High speed and Compact design
- Easy maintenance
- Reliable long term operation
- Quick and excellent After-sales service

Type and Characteristic

Back Pressure Turbine

Back pressure type turbines efficiently utilize a large quantity of process steam, with the exhaust steam available for process heat or for the other steam-driven operations, such as low-pressure turbines.

Condensing Turbine

Condensing type turbines, which are highly economical for variable speed operations, can be directly connected to high speed compressors, thus providing a drive of a minimum initial cost.

Automatic Extraction / Induction Turbine

Where controlled power and process steam pressure are required, the use of the automatic extraction / induction turbine is highly desirable. Within capacity limits, the Mitsubishi automatic extraction turbine can supply varying amounts of extraction steam at constant pressure, while maintaining the required load output by governing the amount of steam admitted to the low-pressure part of the turbine. MCO is well experienced in induction turbine and extraction / induction turbine.

Application line up

Upstream Oil and Gas, LNG, Natural Gas Liquids (NGL), Refinery, Gas to Liquid (GTL)

Downstream Ethylene & Derivatives, Ammonia / Urea, Methanol, Air Separation, Propane dehydrogenation (PDH), Nitric Acid

and other plants including Floating LNG, Industrial Power Generation and so on.



Methanol Plant



Fertilizer Plant



Ethylene Plant



World's first Floating LNG Facility



Mega Ethylene Plant



PDH Plant



PTA Plant
(Integrally Geared Compressor Drive)

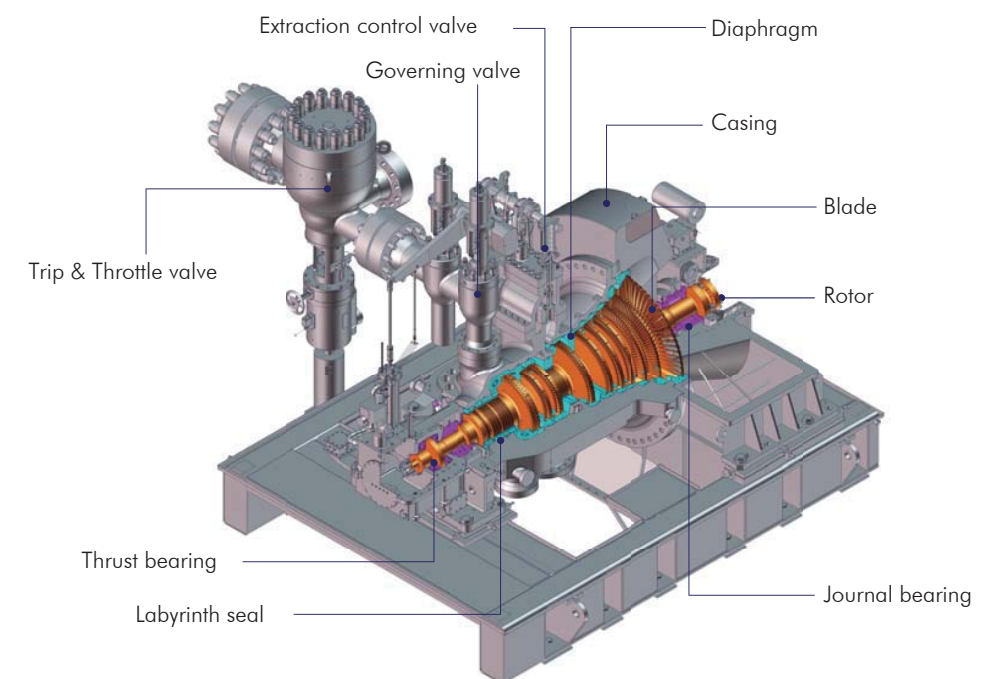

Application Range

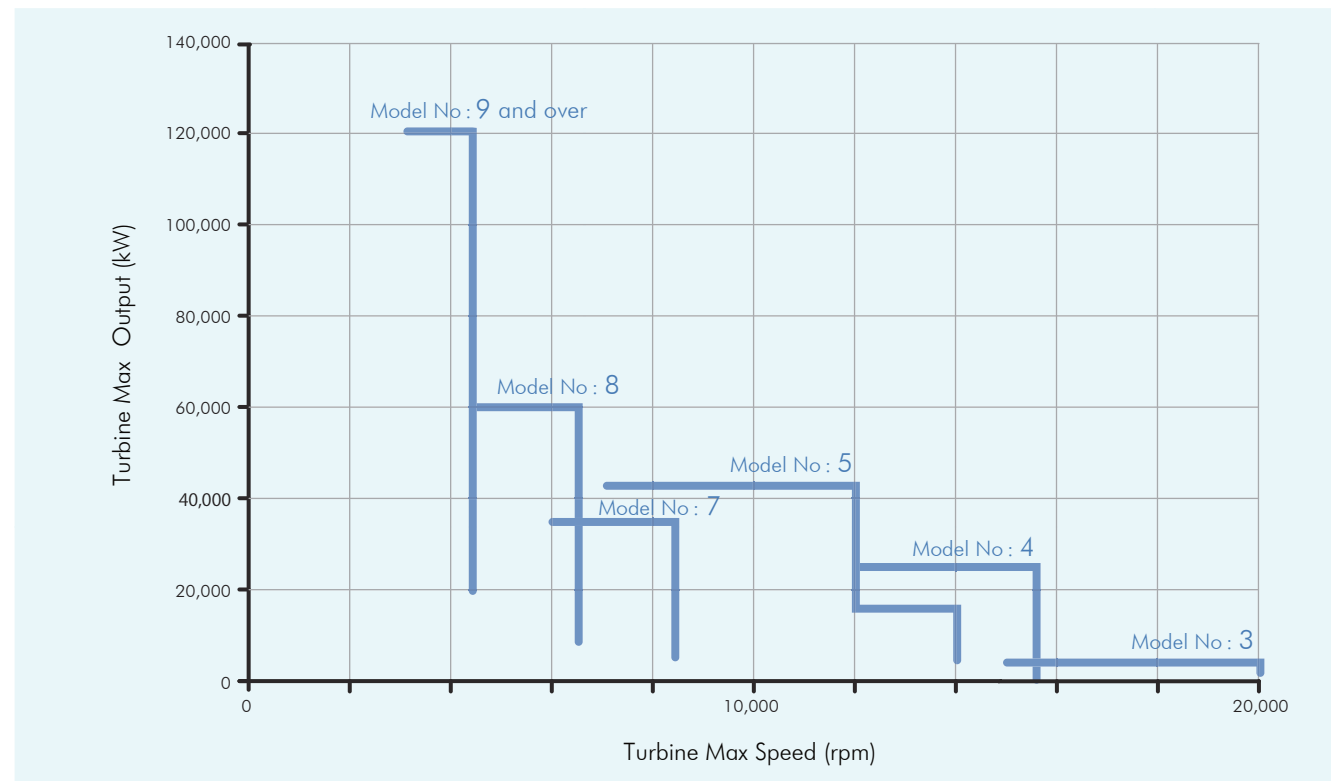

Model Code

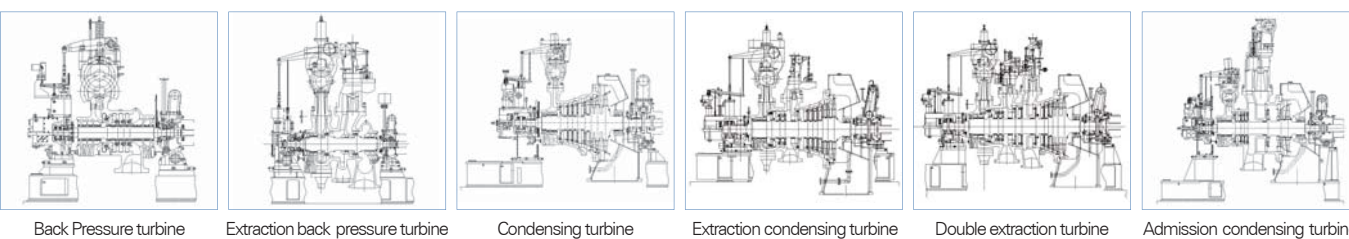
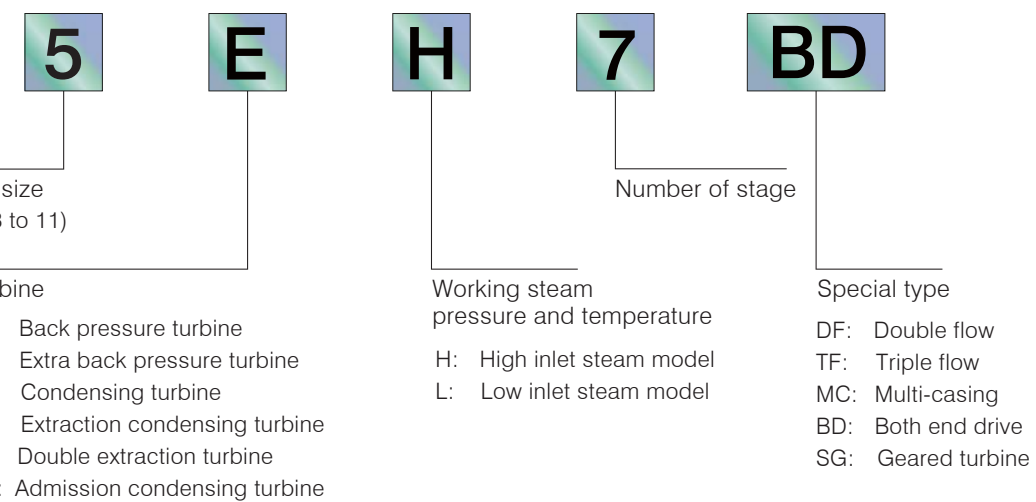

Casing & Support

Center support design, describing below, can align original casing center by absorbing casing thermal expansion during operation. It assures stable operation not only for normal condition but also for start-up, shut down.

- Casing supports, having enough strength to with stand connecting pipe force and moments, can absorb thermal expansion without disturbing shaft alignment.
- Turbine Exhaust casing is fixed point and expands toward high pressure end, which is supported by flexible member absorbing axial expansion.

Labyrinth seal

Labyrinth type packings are applied to shaft end seals and interstage seals to keep minimum clearance between rotor and seal. Labyrinth packings are spring loaded and / or fin is tilted against flow direction to keep minimum clearance and avoid rotor damage even if the rotor contacts with labyrinth fins. In order to minimize leakage steam, slanting labyrinth seals are applied.

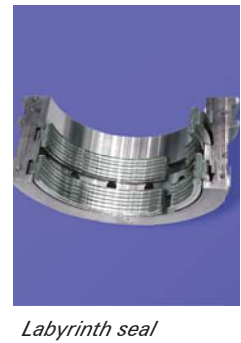

Rotor

Steam turbine rotors are designed and manufactured carefully to realize safety / reliable operation.

- Integral rotor provides stable operation against abnormal vibration due from loosening of shrink fit, fretting and so on.
- Well balanced rotor provides low vibration. Special attention is paid to minimize unbalance in each stage blade assembling. MCO has two high speed balancing machine to achieve the low vibration. This balancing machine can be measured to 20,000 rpm. High speed balance and low speed balance are enough to achieve low vibration operation by this attention, in addition to the design concept of rotor dynamics.



Trip & Throttle Valve (TTV)

MCO can provide two kinds of TTV for inlet steam conditions and customer's requirement.

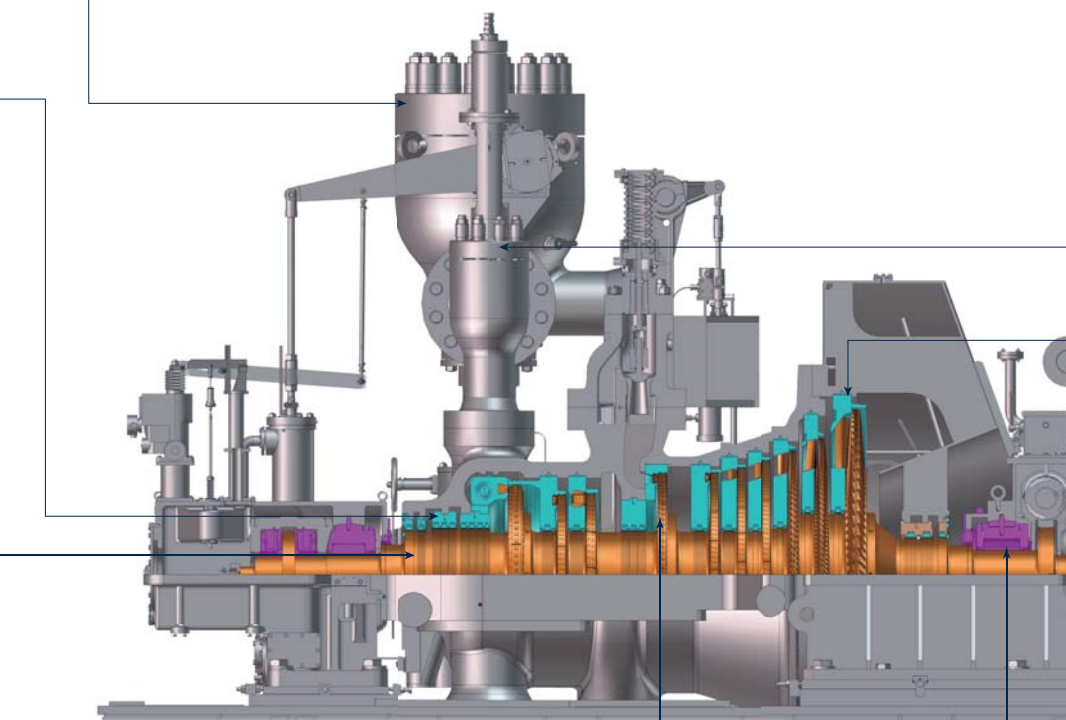
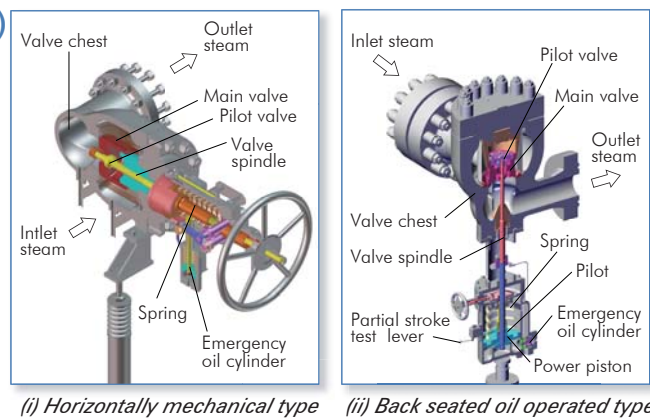

Blade

Ample of experiences not only mechanical drive steam turbines but also power generator drive and laboratory experimental data are fully reflected to the present design to provide the reliability and performance.



Governing Valve (GV) / Extraction Control Valve (ECV)

Multiple-valves assembly minimizes throttling losses and provides for economical operation, both at rated and partial loads. The sequence of opening valves provides a continuous arc of steam admission, minimizing excitation force on rotating blades. For upper portion of the valve chest, hardened bushing that piped to the gland seal system prevent the steam leakage from the steam chest.

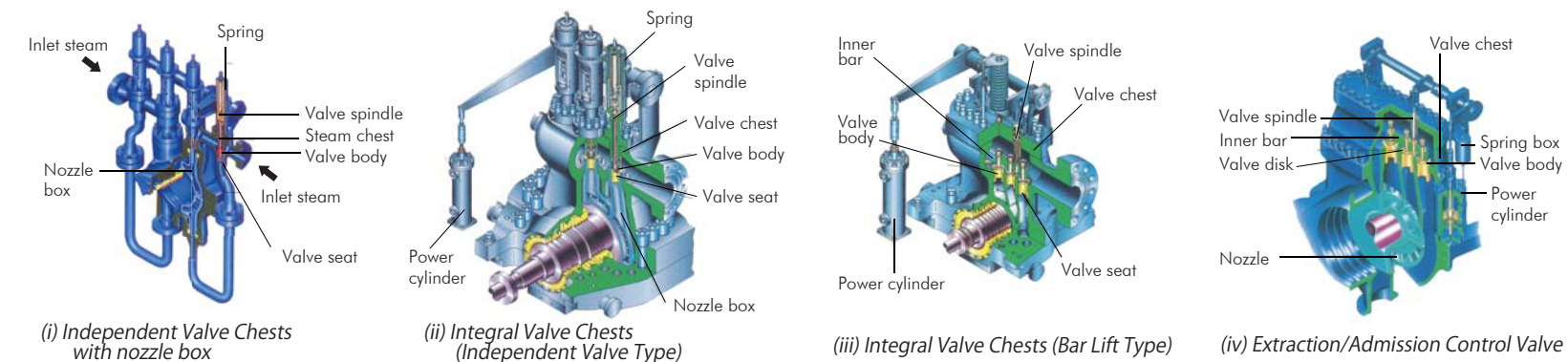

Nozzle & Diaphragm

MCO has developed state of the art profiles to minimize profile loss and secondary flow loss, and applying optimum one to each stage.

- **Nozzle**
Nozzle profiles and configurations are designed to minimize exciting force on moving blades.
- **Diaphragm**
Diaphragms are horizontally split and supported on center lines in order not to disturb shaft centering by thermal expansion.



Bearing

- **Journal bearing**
Direct lubrication type tilting pad design provides excellent heat dissipation feature.
- **Thrust bearing**
Thrust bearing with multi segment pivoted pads and self leveling, can withstand thrust force from either directions and position the rotor accurately.



Start up Philosophy

For turbine start up, MCO has two start up procedure.

- TTV start up

TTV start up is MCO's traditional design. This start up provides the uniform heating of turbine casing. It prevents the deformation of turbine casing due to the unequal heating.

- GV start up

MCO applies GV start up if customer request that procedure. MCO has a lot of experience for this start up. GV start up provides the easy start up for operator.

-Nozzle Box

In case of high pressure and high temperature steam, a separate type nozzle box (Type H) is used to prevent abnormal stress or cracking on casing due to difference in thermal expansion of the steam chests during partial load. These nozzle boxes are supported to compensate thermal growth due to governing valve opening sequence.

Governing system & Safety device

- Governing System

Mitsubishi Mechanical Drive Steam Turbine can employ any type of electronic governor that is available in the market. MCO can provide combined compressor and turbine control system as requested.

- Safety Device

Three safety devices can be applied.

- (i) Dual electro-hydraulic solenoid-operated valve
- (ii) Dual electronic overspeed circuit
- (iii) 2 out of 3 voting overspeed trip device

